



Paw PRINTS

JUNE 2021 | VOLUME 12 | ISSUE 06

**HIGH
OUTPUT**
building the Pontiac 350

**BATTLE
OF THE BRANDS**
volunteers needed!

**BUY
SELL • TRADE**
free ads for members

**FABGTO
SAY HELLO**
to new members Frank & Gail

**COMP
CAMS**
quick tech w/Bradley Brown



SPRING
CRUISE PICS
INSIDE THIS ISSUE!

LETTER FROM THE EDITOR



This is the symbol of
PONTIAC

All I'm saying is that those gals from that Nair commercial back in the day, kicking those legs of theirs up like wannabe Rockettes and belting out that catchy singsong jingle...we wear *short shorts*, if you dare wear *short shorts*, had absolutely nothing on our GTOACO guys! Now mind you, those gals did cause quite a stir during the commercial breaks of One Life to Live and they no doubt sparked more public interest in those slender legs of theirs than in the Royal Teens who first recorded the song Short Shorts in the late 1950's.

Rob Wilson
Founding Treasurer
Current Secretary



Andy Syrkin
Founding Member

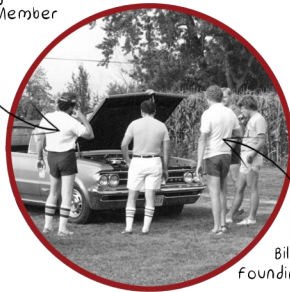

Bill Barton
Founding President



Lonnie McLaughlin
Current Treasurer

But honestly, who could resist some of our muscle car loving men in their short shorts? From tube socks to sandals, and boat shoes with bare feet, our

GTOACO guys have rocked the fashion world for nearly four decades...now let's just hope the manly version of those "Daisy Dukes" and cotton striped tube socks that founding member Andy Syrkin is sporting don't quite so easily make it back into anyone's daily fashion rotation!

And yes Mr. Laughlin, it was your Facebook photo post that inspired me to pick through the archives here at the Wilson household looking for some retro pics of GTOACO short shorts for the June edition.

Here's wishing everyone a wonderful upcoming summer season and a Happy Father's Day!

Karen

On the Front Cover:

GTOACO Spring Cruise 2021
Photo Credit | Ron Cozzo

Contributors:

- Brad Blackburn
- Ron Cozzo
- Frank Fabish
- Lonnie McLaughlin
- Kevin Russo
- Steve Schaeffer
- Rob Wilson

GTO Association of Central Ohio

3866 Riverview Drive
Columbus, Ohio 43221
937-478-0476

INTERIORFEATURES

04 LETTER FROM THE PRESIDENT

Welcome to June as the car community revs up the summertime season!

06 MAY MEETING MINUTES

Battle of the Brands and the All Pontiac Show continue to take shape. Volunteer opportunities available.

11 JUNE CALENDAR

Join us in supporting the Ohio Valley GTO Association at the Milford Cruise-In and wind up the month at the Crosstown Creamery in Tarlton.

12 HIGH OUTPUT

Building the Pontiac HO 350 with Steve Shaeffer.

15 ONE FABGTO

The GTOACO welcomes new members Frank and Gail Fabish to our car club family.

17 BUY•SELL•TRADE

Take advantage of FREE ADVERTISING. All GTOACO members are eligible for no cost advertising, email your ads to the editor today!

20 SPRING CRUISE PICS

What a great day it was for our Spring Cruise. Enjoy the pics provided by Brad Blackburn and Ron Cozzo inside this month's issue and on our Facebook page.

Officers

President

Brad Blackburn
937-478-0476
bradblackburn@dsa-rep.com

Vice President

Kevin A. Russo
740-549-2279
krusso_sp@hotmail.com

Treasurer

Lonnie McLaughlin
614-327-8885
londart@aol.com

Secretary

Rob Wilson
614-519-1019
ro.wilson@att.net

Newsletter Editor

Karen Wilson
614-519-1019
kwilson.1@att.net

Web Master

Austin Cozzo
740-777-1135
acozzo@earthlink.net

Social Media Coordinator

Ron Cozzo
740-777-1135
rcozzo@earthlink.net

Board of Directors

Brent Barham
614-895-8730
bbarham2011@hotmail.com

Brian D'Amico
614-935-5107
burgboy73@gmail.com

Jim Lowry
614-274-0402
JL65Goat@aol.com

Max Treier
740-439-4801
maxwt62@gmail.com





LETTER FROM THE PRESIDENT

By Brad Blackburn

Welcome to June, the month of the summer solstice and the longest day of the year! It also tends to be the month we start to see more and more car shows and cruise-ins hit the schedules. I expect this year to be extra busy do to all the pent-up demand. If the early season Thursday night cruise-ins at the Der Dutchman in Plain City are any indication, let's just say this year's events could be turbo-charged!

May was a great month for our club. First, we were finally back at the Hickory House for an in-person monthly meeting. June's meeting will be at the Hickory House as well...5:30 dinner with our meeting at 7:00. I hope you can join us. On the 15th, we did our spring cruise. The weather was absolutely perfect as we left our meeting point at the Costco in Plain City and traveled approximately 45 minutes to Grimes Field Airport in Urbana Ohio. Upon our arrival, our first stop was the Airport Café (of course there was eating involved) where the food was fantastic. The real tuff choice came when it was time to order desert...7 different, all home-made pies to die for! I think we may need to plan another trip so more flavors can be sampled! Not sure I heard a crowd favorite, but the black raspberry crumb I had was fantastic. Our next stop was the Champaign Aviation Museum where work continues on the restoration of a B-17. The level of meticulous detail involved in following all the original Boeing drawings to restore this aircraft inch by inch is mind boggling. It is amazing how many small pieces it takes to create a 103' 9" wingspan.

Plans are almost complete for our next big event which is our 6th Annual Battle of the Brands car show in Sunbury Ohio. We are expecting a big turn out this year, so please mark your calendars for July 24th. Come out, have some fun, see lots of great cars, and support the club...we need all the volunteers we can get.

Thanks,

The GTOACO was founded in 1984 by a group of GTO Enthusiasts in the Central OH Region. The club name was slated to be the Goat Owners of Columbus but by popular vote at our first meeting we became known as The GTO Association of Central Ohio. Becoming a chapter of the GTO Association of America in 1985, we were incredibly young and determined, hosting our first national show in 1986.

We continue to host and participate in a variety of national, regional, and local events celebrating a kind of camaraderie not easily found. We are car historians, passionately preserving, protecting, and restoring the Pontiac GTO so that future generations will never lose sight of the era that defined the raw power of the American Muscle Car!

TIGERBITES

Noteworthy New Bites

We'll be meeting in person this month at the Hickory House, please join us Wednesday evening, June 9th. Dinner will be available at 5:30 pm followed by the June meeting at 7:00 pm.

Please join us in welcoming new members Frank and Gail Fabish of Westerville, Ohio!

Volunteers are needed for Battle of the Brands, if you can help please contact chairman, **Brian D'Amico** at your earliest convenience.

You can cash in on a Free GTOAA Members Only T-Shirt with a paid membership (limited time—new memberships only). Already a member? Help us update our membership roster by emailing your GTOAA Membership ID# and Expiration Date to the editor at **kwilson.1@att.net**.

On behalf of the Officers and Board of Directors, we wish nothing but the best to all of our members who are celebrating June birthdays and anniversaries. We are truly honored to have all of you as part of our car club family.



MAY 12 • 2021 MEETING MINUTES

The May Meeting was called to order by Vice President Kevin Russo.

In Attendance were Members: Kevin Russo, Lonnie McLaughlin, Rob Wilson, Ron Cozzo, Brent Barnham, Jim Cain, Mamie Cain, Pam Farlow, Stan Farlow, Jeff Frazier, Jeff Inskeep, Jim Lowery, Bill Sigg, and Max Treier.

Treasurer's Report – Lonnie McLaughlin read the treasurer's report. Motion to accept was made by Jeff Frazier, 2nd Brent Barnham.

Battle of the Brands – Kevin reported that the Sunbury Kroger is on board as a sponsor. Jet's Pizza and Big Walnut Grill are looking at co-sponsoring. We're not sure on the number of spaces that will be available for the show yet. The show will be Saturday, July 24th at the Sunbury Kroger parking lot. Volunteers are needed, contact Brad Blackburn or Brian D'Amico.

Spring Cruise – The cruise to the Champaign Aviation Museum in Urbana, Ohio is scheduled for Saturday, May 15th. Kevin mentioned that Brad had asked for all members to RSVP him if they were planning on attending the cruise so that we could provide a lunch count to the Airport Café. Check the Paw Prints for more details.

All Pontiac Show – Ron Cozzo said that he and Kevin Russo are verifying our show date of Sunday, September 5th with the manager of the Quaker Steak and Lube.

Open Discussion – Kevin noted that the Block family will be hosting an open house at their home in Woodsfield, Ohio on Sunday, May 30th to celebrate the life of Debbie Block. If you wish to attend, please check with Stan Farlow or Brad Blackburn for more details.

New members Jim & Mamie Cain introduced themselves.

Jeff Inskeep said that due to the current changes going on at the Columbus Zoo that the cruise to the Wilds probably won't happen this year. Also, the Zoo Car Show is not a sure thing this year either. More information will follow in the Paw Prints as it becomes available.

June Meeting Location – The June meeting will be held at 7:00 pm, Wednesday evening, June 9th at the Hickory House in Gahanna. Pre-Meeting Dinner is available to order starting at 5:30 pm in the meeting room.

Motion for Adjournment – Lonnie McLaughlin, 2nd Jim Lowery.

It is with great sadness that we learned of the passing of long time member, Roy Hess from Xenia who passed on Tuesday, May 11th after a long illness. Roy will be missed, our condolences to Roy junior and the entire Hess family.



Meeting Minutes Submitted By:

Rob Wilson
GTOACO Secretary
614-519-1019
ro.wilson@att.net



JUNE 09 • 2021

MEETING AGENDA

- Establish Quorum
- Call to Order
- Treasurer's Report – Lonnie McLaughlin
- Spring Cruise Report
- Battle of the Brands
- All Pontiac Show
- Open Discussion
- Next Meeting – July 14th (at the Hickory House)
- Motion for Adjournment

MEMBER DUES ARE PAYABLE BY JANUARY 15 • 2021

\$20.00/Year for Members in the USA
(Color PDF Electronic Copy Paw Prints Newsletter)

\$30.00/Year for Members in the USA
(Postal Mailed B/W Print Copy Paw Prints Newsletter)

Make Check / Money Order Payable to:
THE GTO ASSOCIATION OF CENTRAL OHIO

Mail to Treasurer:
Lonnie McLaughlin
5808 Tarton Circle North
Dublin, OH 43017

If you have recently changed your email or postal address, updating your information is easy. Simply message us on **Facebook** or communicate your updates to the club president, Brad Blackburn, via telephone at 937-478-0476 or email at **bradblackburn@dsa-rep.com**.





APPLICATION FOR MEMBERSHIP

Name _____ Date _____

Street _____

City _____ State _____ Zip Code _____

Home Tel: _____ Business Tel: _____ Cell Tel: _____

Occupation _____ Email Address _____

Membership Dues:
 \$20.00/Year for Members in the USA
 (Color PDF Electronic Copy Paw Prints Newsletter)
 \$30.00/Year for Members in the USA
 (Postal Mailed B/W Print Copy Paw Prints Newsletter)

Make Check / Money Order Payable to:
THE GTO ASSOCIATION OF CENTRAL OHIO

Mail To Treasurer:
 Lonnie McLaughlin
 5808 Tarton Circle North
 Dublin, OH 43017

Please provide your GTO Association of America Membership ID# and Expiration Date

Membership ID# _____ **Expiration Date** _____

We encourage all GTOACO Members to apply for membership to the National GTO Association of America. The GTOAA provides many benefits including insurance coverage for club events which is extended to all national chapter clubs (including ours). Membership has its advantages with over three decades of technical knowledge, The Legend monthly magazine, vendor discounts, and access to the National Convention. If you're not currently a member, please consider joining the GTOAA today. For just \$3.00 a month, you can join fellow Pontiac enthusiasts in helping preserve and promote the Pontiac GTO. [Click here to join or renew.](#)

Spouse's Name _____

Child's Name _____ **Child's Name** _____

Child's Name _____ **Child's Name** _____

List the Year, Color, and Style of the GTO(s) or Pontiac(s) that you currently own.

Year	_____	Color	_____	Style	_____
Year	_____	Color	_____	Style	_____
Year	_____	Color	_____	Style	_____

What Club Activities are you interested in?

Thanks for Joining Us! Every Tiger has a Tale, so sit back a few minutes and let's get better acquainted. Please share a short story about yourself, your family, your occupation, or any hobbies you enjoy. Tell us how you became interested in the Pontiac GTO. Include any photographs of your GTO that you would like to share with fellow members. If your story is selected to publish in an upcoming edition of the GTOACO Paw Prints Newsletter, we'll send you a free club t-shirt!



Long Live GAS PEDALS

AND THE FREEDOM OF THE PRESS



REMEMBERING MEMBER
ROY HESS

1947-2021

Photo Credit Tony Webster | tony@twebster.org
Summit Motorsports Park | Norwalk, OH

JUNE • C A L E N D A R

06

CRUISE-IN

SUNDAY JUNE 6TH 2:30PM UNTIL DARK
NO ENTRY FEE - DONATIONS ACCEPTED TO CHARITIES
OVGTO SUPPORTS



**- ALL MAKES AND MODELS
- THE MORE THE MERRIER!**

LET'S GET THIS SUMMER CAR SHOW SEASON STARTED!
TOP 20 AWARDS - MANAGERS CHOICE - SPLIT THE POT
COME OUT ENJOY THE CARS AND GRAB A BITE TO EAT

Ohio Valley GTO Cruise-In

Sunday, June 6
2:30 pm-Dark

Let's get this summer season started with NO ENTRY FEE! Head on over to the Milford, OH **Quaker Steak & Lube** to support The Ohio Valley GTO Association. We'll be splitting the pot, grabbing a bite to eat, and enjoying the cars. Everyone is welcome. Charitable donations accepted. Visit **Ohio Valley GTO** for more information.



Club Meeting

Wednesday, June 9
7:00 pm-8:00 pm

The June Meeting will be held in the meeting room at the Hickory House Restaurant at 550 Offcenter Place in Gahanna. Please kindly notify club president, **Brad Blackburn** if you plan to attend. Pre-Meeting Dinner is available to order starting at 5:30 pm in the meeting room.

09

20

Father's Day

Sunday, June 20
12:00 am-12:00 pm

Inspired by your father, grandfather, or great-grandfather? Let them know by celebrating them this Father's Day. And when a gift card won't do, check out **mancrates.com**. From ammo cans to bacon jerky they've got you covered with unique, high-quality gift ideas.



Crosstown Creamery Cruise-In

Saturday, June 26
5:30 pm-8:30 pm

Head on out to the diner for sweet treats and awards the fourth Saturday of the month now through September 25th. Call Crystal at 740-412-2206 or visit the **Crosstown Creamery** Facebook page for more information. Located at 90 Main Street in Tarlton, OH.

26

BUILDING THE PONTIAC HIGH OUTPUT ENGINE By Steve Schaeffer



No, not the 400 or 455 Pontiac, but the 350. The Pontiac H.O. engine was offered in both the Tempest and Firebird in 1968 and 1969. In 1969 it was rated at 325 horsepower in the Firebird and 330 horsepower in the Tempest at 5,100 RPM.

This was really a smaller bore GTO engine. The bore was 3.88 instead of 4.12. Except for the pistons and rings, all parts interchange. It used the GTO big valve high compression cylinder heads, casting number 48, and the GTO cam. The intake valves are 2.11 inches, and the exhaust are 1.77. This engine was never really a 350. It was actually 354 cubic inches. With a .060 overbore it is 365 cubic inches or 6 liters. Notice that this engine has a factory chamfer in the top of the cylinders to unshroud the valves.

The engine in question is going to be a stock appearing 350 HO going into an original 350 HO four speed '69 Firebird. With a custom grind Comp Cam Hydraulic Roller, and a mild port job on the original HO heads, per Desk Top Dyno 5, it will make 411 horsepower at 6,000 RPM. It will also put out 415-foot pounds of torque at 4,000 RPM. This is going to be for a streetcar, not a drag strip toy.

All the good stuff came from Butler Performance, butlerperformance.com, 866-762-7527.

The Hydraulic Roller Camshaft is a custom grind manufactured by Comp Cam. The advertised duration is 285 degrees on the intakes and 296 degrees on the exhaust. The actual duration at .050 is 230 on the intakes and 240 on the exhausts. The lobe separation is 112.0 degrees.

This cam requires a composite distributor drive gear part number PDG38 from BOP Engineering.

The rest of the valve train are all name brand parts, Johnson hydraulic roller lifters, JL1-21120P. Lunati dual valve springs 73949-16 with 338 pounds of pressure at 1.050 and 120 pounds at an installed spring height of 1.650. Coil bind is at .980. The timing chain set is from Pro Billet JPP-5614.

The roller lifters also require a special valley cover for enough clearance. This also came from Butler. The lifters use a vertical locking bar so they cannot turn sideways in the block and no machining is required. Roller lifters are about .500 taller than stock Pontiac flat tappet hydraulic lifters. You use a checking pushrod that is adjustable in length to determine the correct pushrod length to create the correct valve train geometry for your engine. Order them from Butler, they supply top of the line Smith Brothers chrome

(Continued on page 14)



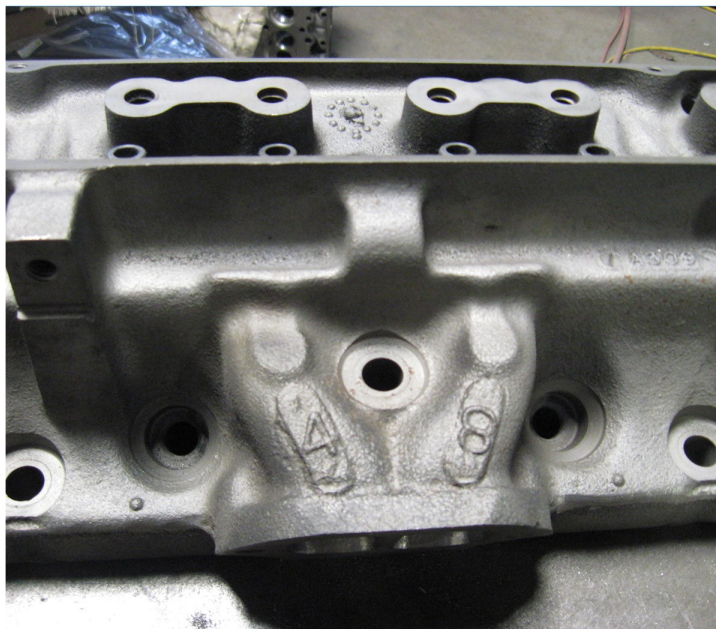
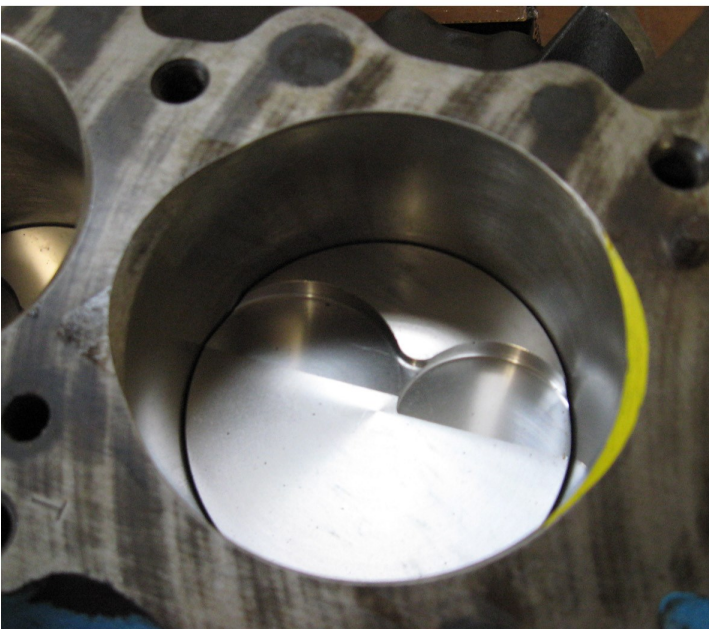
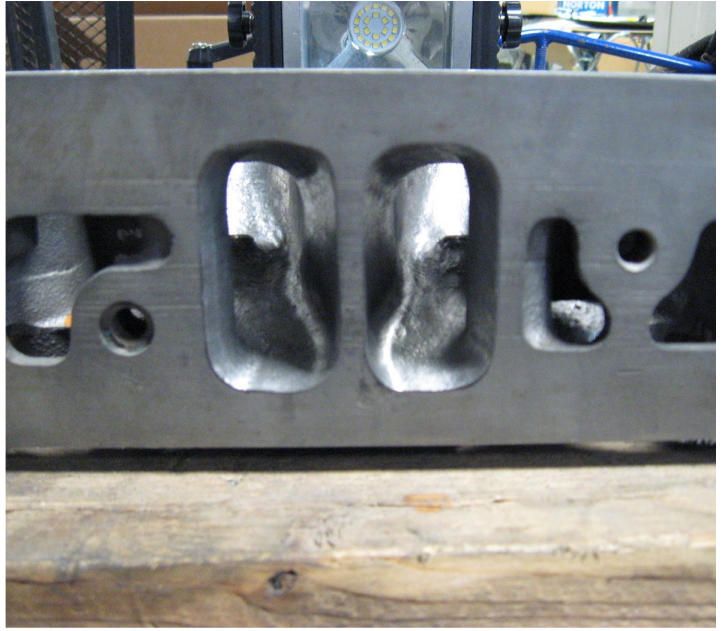
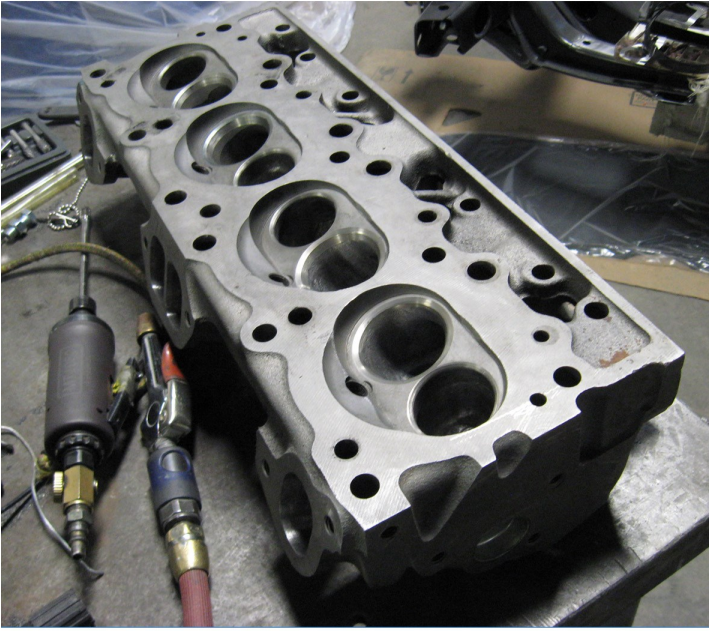

U.S. Patent

Jan. 8, 1980

4,182,290

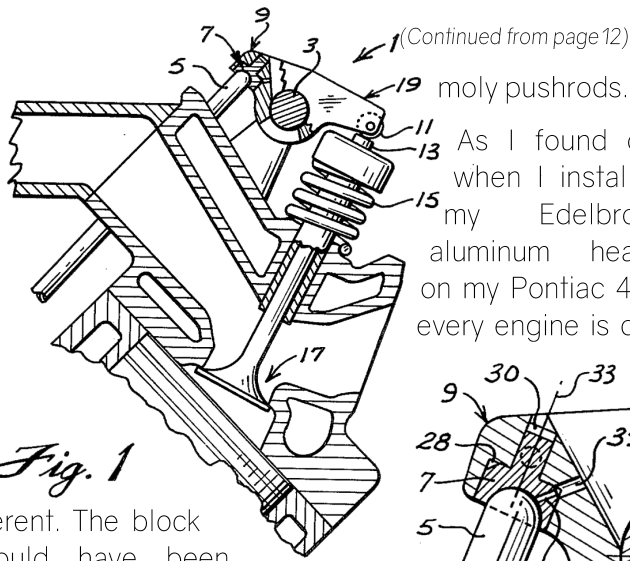

Fig. 1

ferent. The block could have been decked and the heads could have been milled. You need to get the rocker arm geometry right.

We use big block Chevy 7/16 screw in studs in our cylinder heads with poly locks to have an

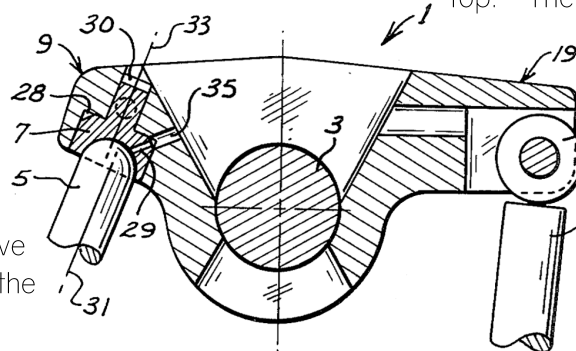

Fig. 3

86 horsepower this is going to be a strong stock appearing engine.

Steve

adjustable valve train. The stock Pontiac rocker studs with the ledge machined in will not work.

Performance GTO heads are already threaded for the screw in rocker studs from the factory. Problem is the factory studs are 7/16 on the bottom and 3/8 on top. The big block

Chevy stud is 7/16 on top

and bottom. I have been using zero

lash plus 1/2 turn to adjust the valves. Check with your camshaft manufacturer. With an additional real

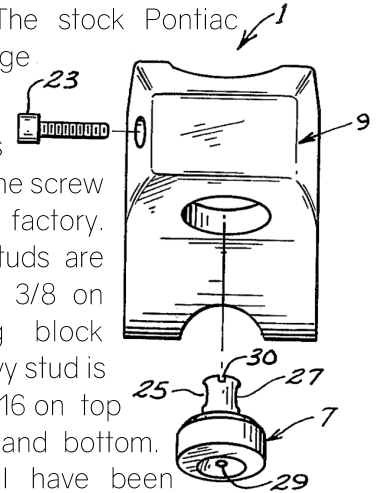

Fig. 2



QUICK TECH

Achieving Proper Rocker Arm Geometry

COMP Cams® R&D Engineer, Bradley Brown, walks us through the steps in how to calculate the right pushrod length for proper rocker arm geometry that will lead to optimum performance, better durability and maximum valve lift. Visit cpgnation.com or [click here](#) to watch the video.

THE GTOACO WELCOMES ONE

FABGTO



Join us all in welcoming Frank and Gail Fabish to our car club family. As Frank puts it, it's been quite a journey returning to those GTO memories from fifty-four years ago.

I have been interested in GTO's since 1967, which was the year that I graduated from West Point Academy and purchased my first car, a 1967 burgundy GTO 4-speed manual, 4-bbl with a black vinyl top. I kept it for four years and had to trade it in after returning from Vietnam and resigning from the US Army as a captain in 1971. I simply couldn't afford two cars.

After founding my family business and working alongside my wife, and son,

Troy at our realty service in Columbus, I retired twenty-three years later.

I have been looking for a 1967 GTO for last four years. It was in Homer City, PA at [Hanksters Hot Rods](#) that I finally found the one I wanted and could afford. Life has been quite a journey since those memories from fifty-four years ago when I first purchased that burgundy 4-speed. It was nothing short of Pontiac excitement when that Brilliant Blue '67 was delivered to the house just a few short months ago. My wife and I have been cruising the Columbus and Westerville area ever since, just enjoying the memories and the cool ride. Now we are just a dude and a babe riding in a cool GTO, sharing our story.

-Frank Fabish

Bottom Left to Right:

Gail and Frank Fabish

One FABGTO

**Our First Car Show Trophy
May 8, 2021 from the 4th
Annual Upper Arlington
Jim Hamilton Car Show**





The

GTO
ASSOCIATION OF CENTRAL OHIO

BWG
BIG WALNUT GRILL

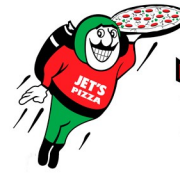

JET'S
PIZZA

HAGERTY
COWLIN
INSURANCE
AGENCY



July 24th, 2021
175 OH-3, Sunbury, Ohio
\$10 Registration from 10:00am
to 1:00pm - Awards at 3:00pm

Come out and represent YOUR car brand!

Awards for "TOP 25"

**...AND BEST CHEVY, BEST FORD,
BEST MOPAR, BEST PONTIAC, BEST
IMPORT & BEST BOC (BUICK-OLDS-CADILLAC)**



For more info:
Brad Blackburn: 937-478-0476 – bradblackburn@dsa-rep.com
Brian D'Amico: 614-935-5107 – burgboy73@gmail.com
NO ALCOHOLIC BEVERAGES PLEASE!
Disclosure: GTOACO, BW Grill, Jet's Pizza and Kroger
are not responsible for ANY Damage or injury

A PORTION OF THE
PROCEEDS WILL
BE DONATED TO:

**Prevent
Blindness**
Our Vision Is Vision®

Rain or Shine All Cars Welcome

BUY • SELL TRADE



SEND US YOUR ADS* FOR JULY BY JUNE 11, 2021
EMAIL THE EDITOR AT: kwilson.1@att.net



Muncie 4 speed transmissions rebuilt for \$275.00 labor, parts extra. The basic rebuild kit consists of front and rear bearings, all needle bearings, gaskets, snap rings, seals, synchro rings, front input retainer nut, synchro keys and springs. Also includes new counter shaft. My cost on the overhaul parts kit is \$126.00 plus shipping. Additional parts, if needed, are at additional cost.

Contact: Steve Schaeffer | Retired A.S.E. Certified Mechanic
 Phone: 740-215-0126 Email: superschaef421@att.net

323 Posi Rear End - \$1200.00. Brand new gears and axles built by Sonic Motors. (Compare to Chevy 12 bolt at \$2600) Please note this is not a used rear end. Best cruising gear to keep your 389 cool. Will deliver to any GTOACO member.

Contact: Greg Nobis
 Phone: 740-815-4748 Email: jgregnobis@gmail.com

DJ GTO Parts is your one stop shop for used and NEW GTO parts located in Central Ohio. All GTOACO members receive a discount!

Contact: Dan Gregory Jr. | Owner
 Phone: 614-563-0877 Email: djgtoparts@gmail.com

Ohio Muscle Car was founded on the idea to treat each project with the highest level of detail and integrity. Whether it is a freshening up of an engine bay or a complete restoration, we pride ourselves on creating a product that each customer can be proud of.

Contact: Kevin Landis | Owner
 Phone: 740-361-1116 Email: ohiomusclecar@gmail.com

ADS* MUST BE FOR CAR PARTS AND THE LIKE, ABSOLUTELY NO HOUSEHOLD OR PERSONAL ITEMS.



THE GTOACO THANKS OUR SPONSORS

*Capital City
Appliance Service*



With more than 40 years in the industry, let Capital City Appliance Service be the team you trust. It's our job to make sure your appliances work. Call our knowledgeable, certified technicians today!

ccas2830@aol.com

www.capitalcityapplianceservice.com

Capital City Appliance Service, Inc.

Jerry Brownfield

2830 Fisher Road, Suite D

Columbus, OH 43204

Phone: 614-308-9028

Fax: 614-308-9034

Toll-Free: 877-308-9028

Business Hours

Monday-Friday 8 a.m-5 p.m.



Quality is why the Hickory House has been in business since 1979. That high level of quality and family tradition, are what keep us going. All our steaks are hand cut from the best available aged, choice cut beef. Never frozen and always U.S.D.A. inspected. We are truly a family owned and operated business. We are three decades strong, and the tradition continues.

www.thehickoryhouse.com

The Hickory House -Gahanna

550 Offcenter Place

Gahanna, OH 43230

Phone: (614) 428-7427

Business Hours:

Monday - Friday: 11am - 9pm

Saturday - Sunday: 4pm -9pm



We buy and sell used and NOS parts for the Pontiac GTO, Lemans, and Tempest, mainly 64-72. We also sell some complete cars and a few parts for Firebird, Bonneville, Catalina, and Grand Prix. Call first for an appointment or stop by the shop.

djgtoparts@gmail.com

DJ GTO Parts

Dan Gregory II

11283 Main Street

Stoutsville, OH 43154

Phone: 740-474-4614

Fax: 740-474-2314



We're proud of the strong roots we've built in our community. Inskeep Printing is a family-owned company that is dedicated to getting you the best quality printing when you need it. Business cards or posters, letterheads or banners, we will work personally with you to get your company what it needs.

www.inskeepbrothers.com

Inskeep Printing Administrative Office

Jeffrey K. Inskeep

3193 E. Dublin Granville Rd.

Columbus, OH 43231-4035

Phone: 614-898-6620

Fax: 614-898-6625

Toll-Free: 888-447-7468

Business Hours:

Monday - Friday 8:00 a.m. - 4:00 p.m.

42nd GTOAA NATIONALS MAKING A SPLASH AT CHULA VISTA RESORT



JULY 5-9, 2021

WISCONSIN DELLS, WI



Hotel: 844.236.6492
Reservation Discount Code: H04446

Tom Oxler: 636.288.1426
Bob Alexander: 970.214.4234
John Owoc: 412.400.5093



www.gtoaa.org



What a GREAT day Saturday was for our Spring Cruise! It was great to revisit the Champaign Aviation Museum to see our club's brick that we purchased to support the effort as well as how much progress has been made on the B-17! The food (especially the PIE!) was fantastic at the Airport Café.

For those of you who went with us the last time, you might remember my friend and former colleague Norm Burmaster who gave us the grand tour and showed us the videos of the team pulling the tail section out of Alaska. I found out during our visit to the museum that he had passed away suddenly in 2018 from Influenza B. Rest in Peace Norm.

Kevin

