

Paw Prints

VOLUME 10 ISSUE 6

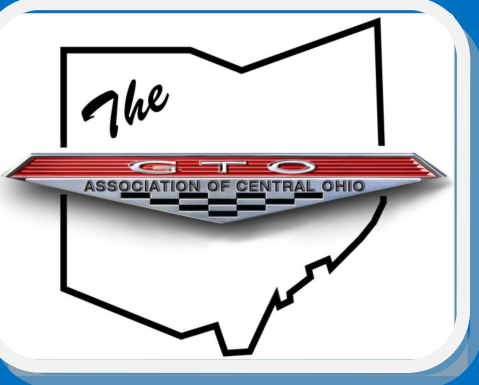

Letter from the Editor - Kevin Russo

SPECIAL POINTS OF INTEREST:

- Spring Cruise
- Blast from the Past

INSIDE THIS ISSUE:

Letter from the Editor	1
President's Letter	2
GTOACO Spring Club Cruise	3
Tiger Bytes/ New Members	6
GTOACO's Blast from the Past!	7
Meeting Minutes	8
Next Meeting Agenda	9
Calendar of Events	10
For Sale	11
Flyers	14
Sponsors	20

Summer is has been kicked off! The unofficial start of the summer is Memorial Day Weekend! I hope you had a great holiday weekend but most importantly, I sincerely hope you took a moment to reflect on what this holiday really means. I hope you took some time to think about those service members that gave their lives, that gave their all and gave the ultimate sacrifice in service of our country. I also hope you went a step further and perhaps thought or even prayed for the family they left behind. God bless them all and my admiration and appreciate is all theirs.

So what's in this edition? Well, the coverage of the club spring cruise. Thanks to Brian

D'Amico for organizing such an amazing event! Also thanks to Stan Farlow for writing the article that is in this month's Paw Prints! I intend to send this piece to Tom Szymczyk for publication in the Legend; The magazine of the GTO Association of America. Hopefully, you'll get to read it twice.

There is also a cool Blast from the Past from Ron Cozzo I hope you enjoy.

Are you getting your car out or are you busy getting it ready for Nationals? I am doing the latter. Are you going to Nationals? I am and I'm planning to help out our friends of the OV-GTO at the event. What about you? Look for the information

from Stan Farlow about how and where to help out if you can, but don't forget to have fun with us too! That's what makes these national events fun, at least for me. Having fun with my club and other Pontiac enthusiasts.

Also, before you know it, our Battle of the Brands and our Indian Uprising shows will be upon us! I hope you'll help us out there too. I know you will.

Until the next meeting or the next car show I see you at, have fun and stay safe!

—Kevin



Club cars ready for a GREAT Spring cruise event!





's Letter

Summer is finally here. It's good to feel some warm temperatures and to spend some time with the GTO and visiting with friends at car shows.

GTOAA Nationals starts June 25 in Lawrenceburg Indiana. Several of us have been in contact with the Ohio Valley GTO Association as it plans and staffs the convention. So far we've been asked to take care of the popular vote tech inspection and help with the popular vote count. I will attend another meeting on June 4th where the intent is to finalize the staffing plan so there may be some more requests for help at that meeting. If you haven't registered for Nationals yet you need to do it very soon as June 1 is the deadline for several events and show classes. After June 1 you can still register but you need to check the calendar for limitations. The website is working well so it's easy to register and I know the Ohio Valley GTO Association folks are anxious to hear from you. This is going to be a good time at a great venue. There are still hotel rooms available at several local hotels. I hope many of you are planning on attending.

Our June 12 meeting will be held at the Big Walnut Grill in Sunbury as part of the preparation for the Battle of the Brands cruise-in on July 27. Brian D'Amico is leading this effort again this year. We expect it to be bigger and better than ever. This is one of our biggest fund raisers of the year and it takes several people to manage the gate, parking, and vote count. We will also be selling t-shirts and staffing the club information table. We are going to need all the help we can get so plan on coming out to support our club.

The car show season seems to be off to a good start. Being on the west side of town Pam and I go to some different shows from the rest of the club. The Heart of Ohio antique mall in Springfield has a cruise-in the first Monday of every month and Der Dutchman in Plain City has a cruise-in every Thursday evening through the summer. Both started off the season with over 100 cars despite much less than ideal weather. I know there are weekly events in Westerville and other places around town. It looks to me like our hobby is alive and well.

Our summers are short, make it sweet, drive your GTO.

Stan Farlow

614-230-4529



2019 GTOACO Spring Club Cruise By Stan Farlow

The GTO Association of Central Ohio is an official GTO Association of America chapter. Our club's goal every year is to kick off the car season with an all Pontiac Swap Meet in March followed by a spring cruise in late April. We always have a good time at both events regardless of the weather April can bring at times in Ohio. In April of 2019, we were blessed with good planning, a good route, and cool sunny weather. Most people think of Ohio as either the flat plains of the northwest or the bluffs over the Ohio River Valley. Some car magazine readers have read articles about road tests that use a well-known route in the Hocking Hills. Central and Southeastern Ohio has many miles of winding 2 lane roads along ridges and valleys that will have you believing that you are no longer in Ohio. This year was our first time on the top of the ridges of state routes 519 and 250 around Adena and Martins Ferry, Ohio. A few club members drove their new generation GTOs, another Firehawk, and a couple of other cars but the older 68, 67 and 70 GTOs and a LeMans owned the day with 60 degree air and winding roads through the hills.

Normally we sort out a good route that leads us to a good restaurant (or winery) with maybe a stop or two at roadside attractions. This year we were fortunate to be hosted by Butch and Liz Miller who brought along Judge Frank A. Fregiato (the same Judge Frank Fregiato who writes the Quarter Mile with the Judge articles in the Legend). We all met for lunch at the Farm Restaurant in Adena Ohio. The Farm Restaurant is on top of a hill far enough out that we had an escort the last few miles to help find it. Far out but well worth the trip to visit this great restaurant.

At the restaurant, we were met by a news team from WRTF from Wheeling, WV for interviews and an evening news story. Club VP Brian D'Amico had quite a bit of time on the Wheeling, WV evening news. Judge Fregiato made an eye opening presentation about activities being promoted by local car clubs to fight the drug problem in Ohio. I always look forward to the Judges articles in the Legend. I didn't know that he presides over the drug court portion of the Belmont County Common Pleas Court.



2019 GTOACO Spring Club Cruise continued



Drug court is a voluntary path for eligible non-violent drug offenders who seek rehabilitation and want an alternative to prison sentences. It is a boot camp style program designed to rehabilitate drug offenders and teach accountability. An example of a drug court accountability practice is the 20, 30, 40 plan. All offenders are required to obtain and keep a job. When an offender states that they are unable to find employment, the requirement is that they perform 20 hours community service per week. If the offender continues to be unable to obtain employment they are required to perform 30 hours per week of community service. It's easy to guess where this is going. It turns out that most offenders, when faced with a full time job doing community service, are able to find some kind of paying job.



I took a bunch of notes during the Judges presentation. In doing some additional research I found this article from the May 2, 2019 issue of the St. Clairsville, OH newspaper "The Times Leader" <http://www.timesleaderonline.com/news/local-news/2018/05/drug-court-no-easy-road-to-rehabilitation/>. It turns out the Judge's efforts have been recognized in the US Senate and were the inspiration for legislation jointly introduced by Ohio and West Virginia Senators (Looks like this is no ordinary county drug court).



Judge Fregiato's attempts to implement existing and develop new practices that improve the courts' outcomes led to the conclusion that the only way to be completely effective was to stop people from entering the drug culture in the first place. Further, it was decided that intervention needed to begin in elementary school and even kindergarten in both public and private schools. To raise funds for the school programs, the "Belmont County Schools Staying Clean Car-Bike-Truck Show Festival" was created. Through extensive use of sponsors, the show has raised over \$63,000 for 2019 and the show isn't until September 14. Local schools are also involved in the planning and conduct of the show. The Belmont Career Center students are making the trophies out of used car parts.



2019 GTOACO Spring Club Cruise continued

The message is that car clubs can make a contribution to their communities.

After lunch and that overwhelming presentation, we proceeded to Butch and Liz Millers “man-cave” in Martins Ferry, OH. We had an escort involving several police cars and lots of lights—not a problem in your windshield but this many lights would be terrifying in your back window. The Millers purchased a building that had been an old time car dealership and turned it into a man-cave with space to work on cars. The garage was well stocked with Pontiacs. Butch’s comment was that every car had a personal story—like the 66 GTO that he sold new, bought back, and restored. The documentation includes all the original dealer related information that most of us could never obtain. Then there is the legendary 1965 GTO station wagon from Canada complete with tri-pwr and close ratio 4 spd. Not limited to GTOs there were 3rd and 4th gen Trans Ams and a couple of 1956s with restoration in the planning phase. Fieros were well represented with a rare 1988 Formula with T-Tops and two very low mileage GTs. Also, there were enumerable die cast cars, go carts, and signs from years past. All in all this is a very nice collection of Pontiacs in a facility that left us all more than a little envious.

As usual the best part of the day was the social interaction between our clubs members and with our incredibly cordial hosts. I always feel good when we can have 30 people together for a day with no drama and everyone having a good time. We certainly want to say Thank-You to Judge Fregiato who took several hours from his busy schedule spend the afternoon with us. Finally, we are indebted to Butch and Liz Miller for their help in planning, arranging for the restaurant and police escorts, and last for opening their wonderful facility for us to visit.

I hope you enjoyed our story as much as we enjoyed sharing it. After nationals, our club will be working on our 2 summer shows and planning to hit the road again this fall.



Tiger Bites! - Noteworthy News Bites

- ◆ Our **2019 Battle of the Brands** show in Sunbury at the Big Walnut Grill is on track for Saturday, July 27. Brian D'Amico is getting preparations together and volunteers will be needed. Look for more news and a call for volunteers to sign up for this great event and see the flyer in the Paw Prints.
- ◆ **The 35th Annual All Pontiac Indian Uprising** is on Sunday, September 1 (Labor Day Weekend) at the Quaker Steak and Lube on Polaris. Volunteers will be needed and a signup will be sent out. See this flyer also in the Paw Prints.
- ◆ If you need to renew or are thinking of renewing your **GTOAA membership, please do so** to ensure our club remains a valid GTOAA chapter with all the benefits of that status. There is an application in your Paw Prints below and the GTOAA can now take membership applications on line. **If you plan to go to 2019 Nationals you must be a GTOAA Member. Please let Stan Farlow know when you join and get your member number in order to keep our roster updated!**

Welcome New Members!

- ◆ No New Members this month

Who's Working on What

- ◆ Ron Cozzoj's 66 LeMans continues to progress and looking great!
- ◆ Lonnie McLaughlin's 65 GTO convertible has its final convertible top and is just about ready for Nationals!
- ◆ Rob Wilson got his 66 GTO convertible back from paint, body and new top installation and is also just about ready for Nationals!
- ◆ Everyone is getting ready for Nationals!

Blast from the Past! by Ron Cozzo

This Blast from the Past is from the July 1985 Paw Prints. These are the installation instructions for the 67 GTO Ram Air kit.

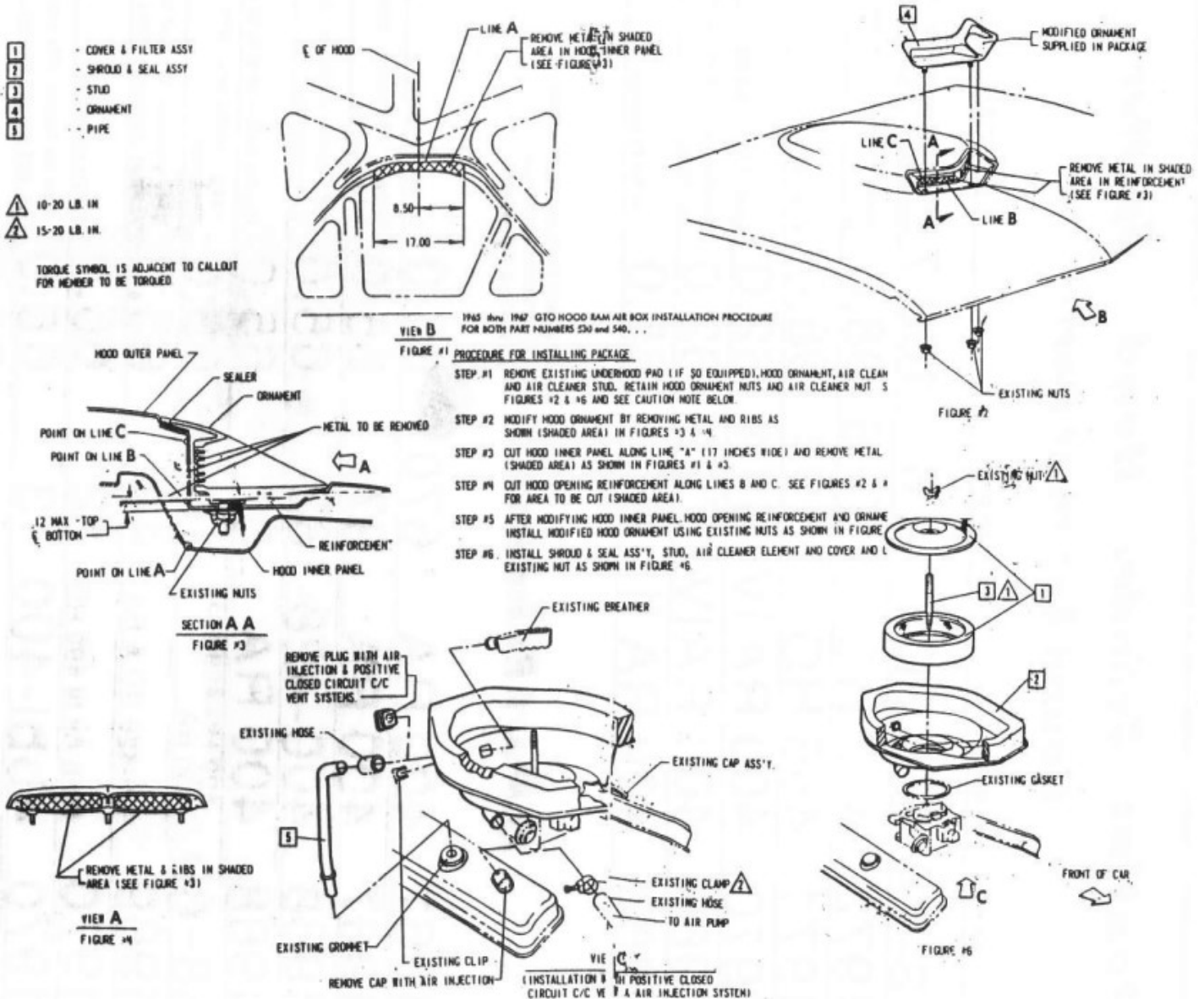

This issue of the Paw Prints (and many others) can be found on our website at [http://www.gtoaco.com/Newsletter/1985 Meeting Minutes/1985 July Paw Prints.pdf](http://www.gtoaco.com/Newsletter/1985%20Meeting%20Minutes/1985%20July%20Paw%20Prints.pdf)



Meeting Minutes April 10, 2019

The meeting was called to order by president Stan Farlow.

In attendance were Pam & Stan Farlow, Kevin Russo, Ron Cozzo, Brent Barham, Max Treier, Bill Sigg, Joe Block, Mike Block, Steve Schaeffer, Brad Blackburn, Jeff Frazier, Jim Lowry, Lance Hudnell, Jim Evans, Mike Berichon, Stephen Leonard and Brian D'Amico.

Treasurer's report – Was presented by Stan Farlow for treasurer Lonnie McLaughlin. Motion to accept by Brian D'Amico, 2nd Brad Blackburn.

Spring Cruise to Martins Ferry Ohio – Thanks to Brian for organizing a GREAT event! Thanks to Ron and Lance for social media promotion and a ton of likes! Cruise was great! A lot of looks from folks, a police escort, a lunch picked up for the club, a great speaker in the Judge and a story on the news and front page of the local paper!

GTOAA Nationals June 25 thru 29 – Lance and Rob went to an OVGTO meeting about the Nationals. OVGTO is getting things moving and on top of things. Lots to go. Schedule for volunteers should come soon.

Battle of the Brands – Brian met with Big Walnut Grill and our June meeting will be there. It may be out last year for the show at the shopping center due to new stores going up in the grass we use for parking. Stay tuned..

35th Annual All Pontiac Indian Uprising — Ron went to the Lube to make sure we are on the calendar for Sept 1 and we are all set. Online promotion to come as well as trophy options.

Overnight trip to “The Gilmore Car Museum” near Kalamazoo Michigan – Lonnie is checking into the venue (museum) and Stan will check on hotel accommodations. It is likely a 5-6 hour drive and a 3 day trip. Stan and Lonnie will put together a schedule and a date to propose to the club.

Up Coming Car Show Discussion – Up coming car shows were discussed. Including Der Dutchman in Plain City Thursdays, Wendell's in Westerville on Wednesdays, the London Strawberry Festival 6/21, Arthritis Foundation Dublin 6/27-6/29, Good Guys 7/12-7/14, Delaware 7/20, Norwalk August 2-4 and Cruise the Ville 8/17.

2020 Swap Meet – will be March 8th at the Franklin County Fairgrounds.

Open discussion – 1. We received our invite to sponsor the Earth Angel Show in Lancaster. Motion by Joe Block and seconded by Brad Blackburn to pay for our customary 1/2 page ad for our Pontiac show. 2. Brian D'Amico going to Pontiacs at Pidgeon Forge if anyone is interested, contact him. 3. Mike Block mentioned the Orphan Car Show in Johnstown 6/8. 4. Mike Berichon discussed this year's Project Blues event in August (project blues.org).

Next meeting location – June meeting will be at Big Walnut Grill in Sunbury.

Motion for adjournment– Brian D'Amico, 2nd Mike Berichon

Submitted by Kevin Russo for Rob Wilson, Secretary



**Meetings
held the 2nd
Wednesday
each month**

ATT: MEMBERS!!!! Please get your dues to Lonnie McLaughlin at 5808 Tarton Circle North Dublin, OH 43017!!

ALL DUES FOR ALL MEMBERS ARE DUE BY JANUARY 15, 2019. Dues for 2019 are \$20 (\$30 for postal mailed newsletter delivery)



Meeting Agenda - June 12, 2019

- Treasurer's Report - Lonnie McLaughlin
- GTOAA Nationals June 25 thru 29– support and sign up
 - Travel Plans—interest in Caravan?
- Battle of the Brands –July 27
 - Volunteer sign-ups
- All Pontiac Club Show— September 1
- Overnight trip to “The Gilmore Car Museum” near Kalamazoo Michigan
 - Overnight in Kalamazoo Mi.
 - Weekend of October 19 (round trip approx. 550 miles)
- Upcoming car shows and cruises.
 - Polaris Hilton every Tuesday evening
 - Wendell's Westerville every Wednesday evening
 - Der Dutchman every Thursday starting 5/23
 - Good Guys 7/12-7/14
 - Delaware Performance Classic 7/20
 - Ames Tri-Power Nationals August 2,3 & 4
 - Cruise the Ville August 17
- Open Discussion
- Next Meeting Location—Hickory House
- Motion for Adjournment

Calendar of Events

June 12, 2019

Regular Club Meeting 7pm @ Big Walnut Grill 175 OH-3, Sunbury, OH 43074. RSVP to Stan Farlow at skfarlow@aol.com if you plan to come. Dinner will be at 5:15pm before the meeting in the same room.

June 16, 2019



Happy Father's Day!

June 25-29, 2019

*The 2019 GTOAA National Convention
Lawrenceburg, Indiana*



JUNE 2019

Sun	Mon	Tue	Wed	Thu	Fri	Sat	
						1	
2	3	4	5	6	7	8	
9	10	11	12	13	14	15	
			<i>Club Meeting @ Big Walnut Grill</i>				
16	17	18	19	20	21	22	
							
23	24	25	26	27	28	29	
			<i>The 2019 GTOAA National Convention!</i>				
30							

For Sale

- ◆ DJ GTO Parts! Now your one stop shopping place for used and NEW GTO parts. If you know the part number, great, otherwise just let them know what it is you need! See Dan Gregory Jr. (or call 614-563-0877 or email info@djgtoparts.com) for more information and options for taking delivery of your parts or visit their website at <http://djgtoparts.com/>. GTOACO members receive a discount!



- ◆ *For Sale—400 Pontiac motor. New build about 500 mi. Comp Cam and accessories, aluminum .intake, water pump and valve covers asking \$1500.00 Harry Mullins 614 795 2310*
- ◆ *I will rebuild your Muncie '64 to '74, Borg Warner T-10 '57 to '64, or GM Super T-10 4 speed transmission for \$400.00 including the following new parts that are necessary to freshen up a worn high mileage unit.*

Synchronizer Rings, Case Bearings, all small parts, spacers, snap rings, needle bearings, thrust washers, strut keys and springs, new counter shaft, gaskets, bushings, and seals.

Shop supplies are additional as are new and used gears, cases, side covers, tail housings, synchronizer assemblies, shift forks, front bearing retainers, etc.

Steve Schaeffer, Retired A.S.E. certified mechanic, Lancaster, Ohio, 740-215-0126.



Send in your items for sale to your Paw Prints Newsletter Editor (pictures welcome).

Remember, ads are FREE to GTOACO Members!



www.gtoaco.com

**APPLICATION FOR MEMBERSHIP
THE GTO ASSOCIATION OF CENTRAL OHIO**

Name _____ Date _____

Address _____ City _____ ST _____ Zip _____

Home Phone _____ Cell Phone _____

Occupation _____ E-mail Address _____

Membership Dues are \$20/yr for email Paw Prints delivery, or \$30/yr for postal delivery.

RECEIVE OUR MONTHLY NEWSLETTER, THE PAW PRINTS (Check One)

BY EMAIL (COLOR PDF) \$20
OR POSTAL MAIL (BLACK AND WHITE) \$30

MAKE CHECKS PAYABLE TO: **THE GTO ASSOCIATION OF CENTRAL OHIO**

SEND TO: **Lonnie McLaughlin**
5808 Tarton Circle North
Dublin, OH 43017
614-327-8885
londart@aol.com

ARE YOU A MEMBER OF THE GTO ASSOCIATION OF AMERICA # _____ Date Expires _____

SPOUSE'S NAME _____

CHILDREN _____

YEAR, COLOR AND STYLE OF GTO (s) OR PONTIAC (s) CURRENTLY OWNED

WHAT ACTIVITIES WOULD YOU BE INTERESTED IN? _____

OPTIONAL:
WRITE A SHORT STORY ABOUT YOURSELF, FAMILY, OCCUPATION, HOBBIES AND HOW YOU GOT INTERESTED IN GTO'S. IF YOU HAVE ANY PICTURES OF YOUR CAR SEND THOSE ALSO. THIS INFORMATION WILL BE USED IN A COLUMN IN THE PAW PRINTS FEATURING MEMBERS. IT IS A GOOD WAY FOR US TO BECOME AQUAINTED WITH EACH OTHER.



GTOAA Information

Your chapter is an affiliated chapter with the GTO Association of America. You can join the National GTO organization, the GTOAA & receive the Golden Quill Award Winning publication, *The Legend*.

To join complete the form below and mail in, or join online at www.gtoaa.org



Membership Application

Date: _____

Mem #: _____

Name: _____

Phone: _____

Address: _____

Email: _____

GTO Ownership is not a requirement of membership to the GTOAA

GTO OWNERSHIP

Year _____ Body Style _____ Engine _____

Year _____ Body Style _____ Engine _____

Year _____ Body Style _____ Engine _____

I agree that, if elected to membership, I will conform to all rules of the Association and conduct myself in the manner that promotes the goals and purposes of the Organization.

Signed: _____ Date: _____

DUES:
\$35.00/year for members in the USA, \$40.00USD/year for Canadian members, and \$50.00USD/year for all other international members. \$5.00 for associate memberships in the same family name (includes membership card, decal, and membership listing). There is a \$2.00 bank processing fee for applications paid by credit card.

CHECK / MO # _____

Mastercard / Visa Card # _____ Exp # _____

Signed: _____ Date: _____

Make Check/Money order payable to GTOAA:

Mail signed Application to: GTOAA, PO BOX 455, Timnath, CO 80547



GTOAA CHAPTERS

HERE IS YOUR CHANCE TO HELP THE **PONTIAC OAKLAND MUSEUM**

Your chapter can sponsor one of the 23 Classes
at the 8th Annual GTOAA Pontiac Museum Regional
September 21 – 22, 2019

The cost is just **\$100** per class and your GTOAA Chapter
will get special recognition with your Chapter on the 1st,
2nd & 3rd place trophies, listing on the Car Class Fliers
given to every registrant and announced during the
Awards Ceremony on Sunday afternoon.

For more info contact Tom Oxler at 636-928-5548 or at toxler@prodigy.net

Make checks payable to Gateway GTO Assoc. and mail them to me at 450 Muirfield Dr. St. Charles, MO 63304





BWG
BIG WALNUT GRILL



**JET'S
PIZZA**

HAGERTY
COWLIN
INSURANCE
AGENCY



GMC



CHRYSLER



LINCOLN



Mercedes-Benz



SUBARU



TOYOTA



ISUZU



PONTIAC



Jeep



Cadillac

HUMMER



Audi



JAGUAR



PORSCHE



HONDA



MIITSUBISHI



ACURA



KIA



SUBARU



NISSAN



INFINITI

July 27th, 2019
175 OH-3, Sunbury, Ohio
\$10 Registration from 10:00am
to 1:00pm - Awards at 3:00pm

Come out and represent YOUR car brand!

Awards for "TOP 25"

**...AND BEST CHEVY, BEST FORD,
BEST MOPAR, BEST PONTIAC, BEST
IMPORT & BEST BOC (BUICK-OLDS-CADILLAC)**



MUSIC PROVIDED BY:

~DJ Meeko~

Brian D'Amico
DJ / Track Master
Weddings / Parties / Events (Big or Small)

For more info:

Brian D'Amico: 614-935-5107 - burgboy73@gmail.com

NO ALCOHOLIC BEVERAGES PLEASE!

Disclosure:

GTOACO, BW Grill & Jet's Pizza are not responsible for ANY damage or injury

A PORTION OF THE
PROCEEDS WILL
BE DONATED TO:

 **Prevent
Blindness®**
Our Vision Is Vision®

Rain or Shine All Cars Welcome

September 1, 2019

Rain or Shine



35th Annual ALL PONTIAC



INDIAN UPRISING



CAR SHOW

Hosted by: *The GTO Association of Central Ohio*

Quaker Steak & Lube, 8500 Lyra Dr, Columbus, OH 43240

This show is points judged with 13 All Pontiac Classes. Pontiacs or Oakland Vehicles only please. Additional registration information on reverse side.



REGISTRATION 8:00AM - NOON
SHOW JUDGING NOON - 3:00PM
AWARDS 4:00PM

For show information contact:
Ron Cozzo (740) 777-1135, rcozzo@earthlink.net
or
Kevin Russo (740) 549-2279, krusso_sp@hotmail.com

Or visit www.gtoaco.com



www.gtoaco.com



A portion of the proceeds from this event will be donated to Prevent Blindness Ohio

September 1, 2019

Rain or Shine



www.gtoaco.com



Quaker Steak & Lube, 8500 Lyra Dr, Columbus, OH 43240



OFFICIAL REGISTRATION FORM

1 - Complete Registration Info

Name _____ Telephone _____ Cell phone _____
 Address _____ City _____ State _____ Zip _____
 E-mail _____ Club Affiliation _____
 Pontiac: Year _____ Model _____ Body style _____ Color _____

One car per registration form.

2 - Choose your class

6 - GTO CLASSES

- A 64-67 STOCK GTO
- B 68-74 STOCK GTO
- C 65-71 STOCK CONV. GTO
- D 64-74 MODIFIED GTO
- E 04-06 STOCK GTO
- F 04-06 MODIFIED GTO

3 - FIREBIRD CLASSES

- G 67-81 STOCK FIREBIRD
- H 82-02 STOCK FIREBIRD
- I ALL MODIFIED FIREBIRD

5 - OTHER PONTIAC CLASSES

- J PRE-1965 STOCK PONTIAC*
 - K 1965 - 1976 STOCK PONTIAC
 - L 1977 - & UP STOCK PONTIAC
 - M ALL MODIFIED PONTIAC
- *Oakland Included

5 - GTOACO CLASSES**

- P 64-67 STOCK GTO
- Q 68-74 STOCK GTO
- R 64-74 MODIFIED GTO
- S 04-06 GTO
- T ALL OTHER PONTIACS

** no awards or fee for club cars

3 - Pay in advance or day of show

Entry Fee
Before August 1 \$10 _____

Day of Show \$15 _____

Spectators are free.

Vendors please inquire to
rcozzo@earthlink.net

Make check payable to:
GTOACO
and mail to:
Ron Cozzo
1710 Buttermilk Hill Rd.
Delaware, OH 43015
Before August 1

The above class breakdowns are preliminary and subject to change. No alcoholic beverages please.
GTOACO and Quaker Steak & Lube are not responsible for any damage or injury.

For Fun Come to the Eighth Annual...

GTOAA REGIONAL ALL PONTIAC

CRUISE AND SHOW

proceeds benefit the Pontiac-Oakland Museum

Celebrating 50 Years

THE JUDGE



Hosted by the...

Heart of Illinois GTO Club

Gateway GTO Club

Windy City GTO Club

Pontiac, Illinois
Entertainment, Tours,
Shows, Cruise, Fun & More



Pontiac-Oakland Museum
& RESOURCE CENTER

205 N. Mill Street • Pontiac, Illinois 61764

Phone • 815-842-2345

www.pontiacoaklandmuseum.org

September 21 - 22, 2019

For Information Contact :

Mark Melrose
314-807-2520

mjmelrose@aol.com

Brian Sorensen
630-991-1465

bsorensen1@comcast.net

both days \$30 Sunday only \$20

for registration & info, see www.gatewaygto.org

Saturday • Private Collections • Tour
• Entertainment • Ice Cream Social
Sunday • All Pontiac Car Show
• Expanded Classes • Special Judge Display

Hotels

- Hampton Inn 815-844-4400
- Quality Inn 815-844-4444
- Super 8 815-844-6888
- Best Western 815-842-2777

GTOACO Club Officers

President

Stan Farlow
1810 Uppervalley Dr.
West Jefferson, OH 43162
614-879-9923
skfarlow@aol.com

Vice President

Brian D'Amico
127 S Vernon St.
Sunbury, OH 43074
614-935-5107
burgboy73@gmail.com

Treasurer

Lonnie McLaughlin
5808 Tarton Circle North
Dublin, OH 43017
614-327-8885
londart@aol.com

Secretary

Rob Wilson
P.O. Box 360
Lithopolis, OH 43136
614-519-1019
ro.wilson@att.net

Newsletter Editor

Kevin A. Russo
3175 Arctic Ave.
Lewis Center, OH 43045
740-549-2279
krucco_sp@hotmail.com

Web Master

Austin Cozzo
1710 Buttermilk Hill Rd.
Delaware, OH 43015
740-777-1135
acozzo@earthlink.net

Social Media Coordinator

Ron Cozzo
1710 Buttermilk Hill Rd
Delaware, OH 43015
740-777-1135
rcozzo@earthlink.net

Board of Directors

Kevin A. Russo
3175 Arctic Ave.
Lewis Center, OH 43035
740-549-2279
krucco_sp@hotmail.com

Brent Barham
218 Spring Hollow Lane
Westerville, OH 43081
614-895-8730
bbarham@redbuilt.com

Jim Lowry
2667 St. Patrick Rd.
Columbus, OH 43204
614-274-0402
JL65Goat@aol.com

Max Treier
711 N. 13th St.
Cambridge, OH 43725
740-439-4801
maxwt62@roadrunner.com



GTOACO Sponsors



Inskeep Brothers Printing

Jeffrey K Inskeep

3152 E Dublin-Granville Rd

Columbus, OH 43231

614-898-6620

4print@inskeepbrothers.com

<http://www.inskeepbrothers.com/>



DJ GTO Parts, Inc.

Rust Free Parts & Cars Bought & Sold

Dan Gregory, II

11283 Main St

Stoutsville, OH 43154

740-474-4614

info@djgtoparts.com

<http://djgtoparts.com/>



Capital City Appliance Service

Jerry Brownfield

2830-D Fisher Rd

Columbus, OH 43204

614-308-9028

ccas2830@aol.com

<http://www.capitalcityapplianceservice.com/>

2010-2018 GTOA Newsletter Certificate of Excellence Recipient

JUNE 2019

A Publication of the GTO Association of Central Ohio

614-879-9923

West Jefferson, OH 43162

1810 Upper Valley Dr.

Stan Farlow



2010—2018 GTO Association of America Newsletter
Certificate of Excellence Award Recipient



**Paw
Prints**